

GUIDELINES FOR WELDING THERMOPLASTIC MATERIALS (Hot Gas Hand and Hot Gas Extrusion Welding)

TABLE OF CONTENTS

- I COMMON THERMOPLASTICS AND WELDING TECHNIQUES**
- II HOT GAS (AIR) WELDING**
 - 1 The Process in General
 - 2 The Hot Gas (Air) Generating Equipment
 - 3 Material Preparation
 - 4 Tack Welding
 - 5 High Speed Welding
 - 6 Free Hand or Fan Welding
 - 7 Weld Design
 - 8 Heat Stress Problems
- III HOT GAS (AIR) EXTRUSION WELDING**
 - 1 General
 - 2 Equipment and Procedure
 - 3 Visual Check of the Final Weld
- IV TESTING**
- V TEMPERATURE RECOMMENDATIONS**
- VI BEAD SIZE RECOMMENDATIONS**

The information contained within are mere guidelines for welding thermoplastic materials. More detailed information is available through DVS standards established by the GERMAN WELDING SOCIETY. Please contact our company for further information.

I. COMMON THERMOPLASTICS AND WELDING TECHNIQUES

There are a number of methods to weld thermoplastics, which include hot gas (air) hand welding, hot gas (air) extrusion welding, butt fusion (heated element welding), friction welding, laser welding and high frequency welding. In the following, hot gas (air) hand welding and hot gas (air) extrusion welding are being addressed since they play a major role in the field of custom thermoplastic fabrication. A further application for these techniques is the modification or repair of rotationally molded, blow molded, vacuum formed or injection molded parts.

The most commonly welded thermoplastic materials are

Polypropylene	-	PP
Polyethylene	-	PE
Polyvinylchloride	-	PVC
Chlorinated Polyvinylchloride	-	CPVC
Polyvinylidene fluoride	-	PVDF

Other materials such as ABS, PS, PC and PMMA are welded on a more limited basis and are not covered here in any detail.

Welding means raising the temperature of the materials to their **thermoplastic state**, applying pressure to allow the molecules to newly position themselves and thus creating a new homogeneous area when cooled down. The thermoplastic state, i.e. the temperature range in which the material is weldable, differs between materials. Compared to PP and PE, PVC and CPVC have a very small thermoplastic state, i.e. the temperature window for welding is relatively narrow.

Compatibility between materials is an important factor. It is recommended to verify that the melt flow rates of HDPE materials to be welded together are the same or neighboring. With PP it is not recommended to use Homopolymer rod with Copolymer parent material.

Hot gas (air) hand welding and hot gas (air) extrusion welding are manual operations and require the use of a filler material. The quality of the weld is highly dependent on the knowledge and skill of the operator. The operator needs to be knowledgeable in both the set up of the equipment and the proper execution of the weld

II. HOT GAS (AIR) WELDERS

1. THE PROCESS IN GENERAL

In hot gas (air) welding, the heat transfer medium is a heated gas, in general clean air. In the infancy of plastic welding, the use of Nitrogen proved most successful in preventing material contamination and oxidation. With today's material quality and equipment technology, Nitrogen is becoming more and more a relic of the past. The combination of clean, oil and moisture free air with controlled temperature proves equally successful, eliminating the continuous expense of the inert gas. The temperature of the hot air ranges between 250°C (480°F) and 550°C (1022°F) depending on the type of material (different melting points), material mass to be risen in temperature (usually the material thickness) and the environmental conditions under which the welding process takes place.

2. THE HOT GAS (AIR) GENERATING EQUIPMENT

The air flows through a hot gas (air) hand welding gun where it is heated up by an electrical heating element. Two principles are used to control the air temperature. The older principle uses a constant wattage heating element and varies the amount of air flow in order to increase or decrease the air temperature. The drawback to this method is that in general a much wider area than necessary is heated up. This introduces heat stress related problems into the material that may cause cracks based on the material expansion and contraction factors.

The newer method of controlling hot air temperature involves the use of electronic circuitry to control the actual applied wattage of the heating element using a constant, minimal air flow. This provides for minimum heat transfer into the base material without sacrificing weld quality. The second advantage of electronic controls is a safety feature preventing burn out of the element or melt down of the gun in case of air flow interruption.

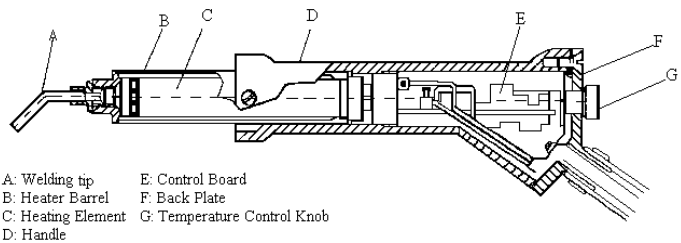

The latest trend in developing electronic controls for hot air heating elements incorporates closed loop controls that hold the temperature constant even while air flow or supply voltages fluctuate.

Rotary vane or regenerative blowers provide clean air at a high volume but low pressure and are therefore the ideal air supply for thermoplastic hand welding. It is possible, however, to use regular shop compressors provided their airflow can be adjusted with an air flow meter (not pressure gauge) to the required air volume. The major drawback is keeping oil and moisture out of the compressed air.



An alternative to generating the necessary airflow would be to use "self-contained" welding guns that have a blower built in. The main drawback to using a self-contained welding gun is its size and weight (operator fatigue). Generally, they are used only for repair work, small installations or on job sites.



An equally important factor in hot gas (air) welding is the style and type of welding nozzle (tip). Their function is to properly distribute the hot air onto the parent sheet and to heat up and guide the welding rod in the high speed welding process. A variety of tips are available for specific applications. In the field of plastics fabrication, the most common nozzles are the round (freehand), tacking, high speed and the combination high speed welding and tacking tips.



Round Tip



Tacking Tip



High Speed Tip



Combination High Speed/Tacking Tip



High Speed Tip for Triangular Profile Rod



Combination Tip for Fluoropolymers and PVC

3. MATERIAL PREPARATION

A good homogeneous weld requires proper preparation of the material. The part should be free of any impurities such as dirt, oil, etc. Additionally, some thermoplastics develop a thin layer of oxidized molecules on the surface that have to be scraped or ground off. Another effect, especially with HDPE, is the migration of unchained, lower density molecules to the surface caused by internal pressure of the material. This gives the usually "waxy" surface appearance of PE. Grinding or scraping the weld area is therefore strongly recommended. Any dust should be wiped off with a clean cloth. Solvents or cleaners should not be used since they introduce chemicals with unknown and possible adverse effects. Scraping needs to be done just prior to welding and repeated after each pass in the event of multiple pass welding. For welds that have to comply to DVS guidelines, the welding rod has to be scraped as well.

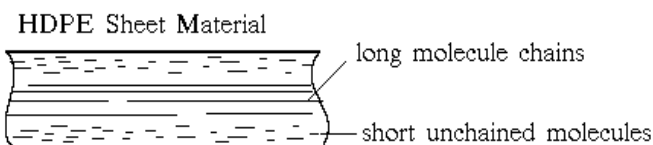

4. TACK WELDING

The initial step in the welding process is the "tack weld." The objective is to put the parts into place, align or realign them and to prevent slippage of the material during the structural welding process (high speed weld, extrusion weld, etc.). A tack weld is easily broken apart if anything is out of alignment, whereas a structural weld requires more work and time to be removed. Common sense should determine whether an intermittent or continuous tack weld is applied. Larger structures and thick gauge materials may even require additional clamping.



Tack Welding

5. HIGH SPEED WELDING

As far as hot gas (air) hand welding is concerned, more than 90% of the structural welds are high speed welded. In this process a filler material, the welding rod, is introduced into the seam to give supportive strength. Standard rod profiles are round and triangular. Triangular rod is applied where cosmetic appearance is important, e.g., furniture, laboratory equipment, etc. It can only be used as a single supportive weld and does not allow for the kind of surface penetration that can be achieved with round welding rod.

Round welding rod is used where "heavy duty" welds are required. It allows the fabricator to lay several beads of welding rod on top of each other. This way, a relatively thin welding rod can be used to produce a strong weld even on heavy gauge material. Common rod diameters are 1/8, 5/32, 3/16, 1/4" and their metric equivalents 3, 4, 5, 6mm.

The design of the high speed welding nozzle needs to satisfy 3 conditions: preheating the base material, guiding and preheating the welding rod and allowing for the application of pressure on both the rod and sheet.

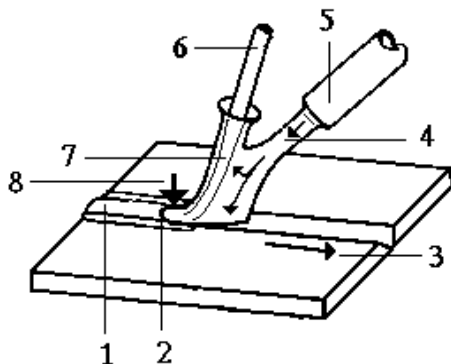

1. Welding Bead
2. Wash
3. Welding Direction
4. Hot Air
5. Air Heater
6. Welding Rod
7. Welding Rod at Plasticized State
8. Pressure

It is important to select the correct diameter tip for the selected welding rod. An oversized nozzle will negatively affect the guidance and applied pressure and may also cut into the parent sheet.

For quick and trouble-free change over from tacking to high speed welding, a combination nozzle with both features prevents worn tip threads and burnt fingers.

Additional lighting may be recommended for working inside darker structures .

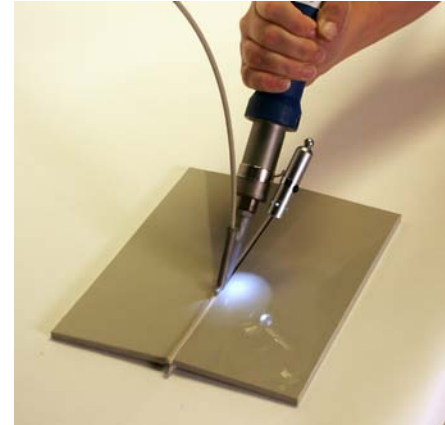

6. FREEHAND OR FAN WELDING

The oldest method of welding with filler rods is freehand or fan welding. This process is much slower than high speed welding but it must be used where very small parts are being welded (small fittings) or where the available space prohibits the use of high speed welding tips. The only nozzle used in this process is a small jet pipe with an opening of 1/8" or 5/32" to concentrate the heat. The operator has to wave the nozzle at the base material and the welding rod with an "up and down" and "side to side" motion in order to bring them both into the plasticized state. The necessary pressure on the welding rod is hand applied by pushing down on it vertically at a 90° angle. When the correct amount of pressure and heat are applied to the rod and base material, a small wave of molten material can be seen right in front of the welding rod. If bent backwards, the welding rod will be stretched and thinned out; if bent forwards, no wave will occur in the front and insufficient pressure will be applied to achieve a good weld. Fan welding, especially over a long period of time, requires a highly skilled operator and should be avoided if a simpler method of welding can be utilized.

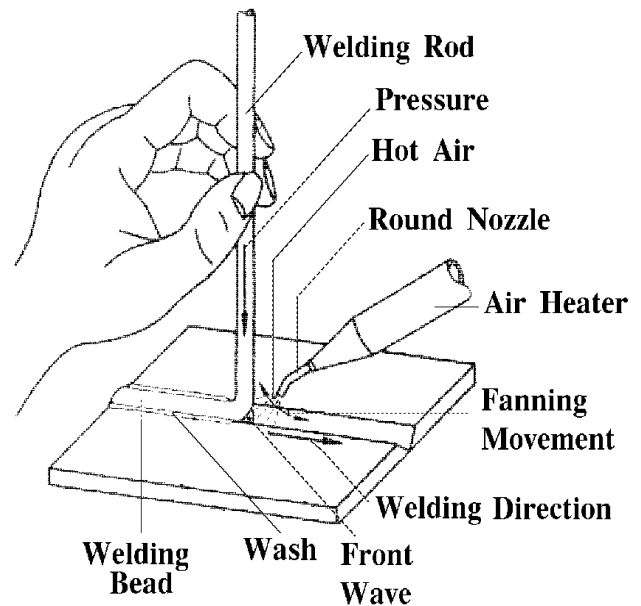

7. WELD DESIGN

There are a great number of bead forms that can be specified; the most common ones are shown on the below. Certain aspects must be taken into consideration before starting to weld. A smaller diameter welding rod is preferable to a large one since it is easier and faster to control the plasticizing process. The disadvantage is that multiple beads are required for thicker gauged sheet. This could cause excessive heat stress due to the alternating heating and cooling cycles. Therefore, it is sometimes advisable to choose a different method of welding, e.g., hot gas (air) extrusion or heated tool (butt) welding. Heat stress should also be taken into consideration when bead forms are selected. For example, a butt joint performed with a double V design will generate less stress than a single V design. Here, both sides of the base material are heated up an even amount of times, which equalizes the expansion and contraction cycles.

Another consideration is the human factor. Hot gas (air) hand welding depends heavily upon the skill of the operator, and sufficient safety margins should be designed into the finished product. A little extra time spent on proper design and fabrication will help you to avoid the headaches caused by improper design and hastily performed welds.

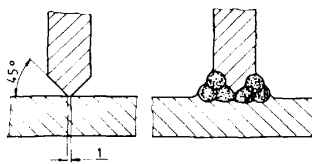

Double T-Joint

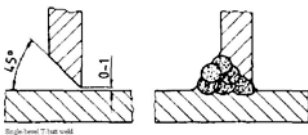

Single T-Joint

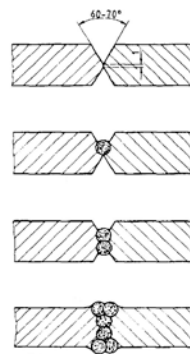

Double V-Joint

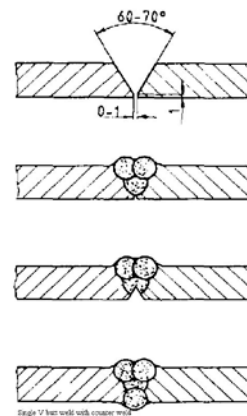

Single V-Joint with counter root

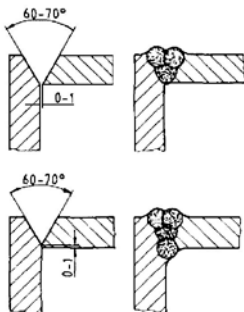

Single V-Joint without and with counter root

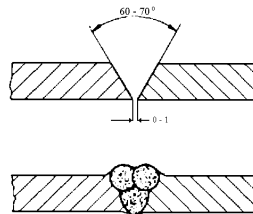

Single V-Joint

8. HEAT STRESS PROBLEMS

We will discuss heat stress in a little more detail in this section. Physical law dictates that when materials are heated they expand, and they contract when cooled. This is known as the coefficient of linear thermal expansion. Compared to metals, thermoplastics have a much higher expansion factor under identical temperature conditions.

During hot gas (air) welding, the material will expand while it is forced into a given position by the welding rod. When cooling down, it will shrink back to its original volume but since it is fixed, it will not shrink to its original shape. A sheet that was straight may now be bowed. Due to their flexibility, thin gauge materials may be bent back into their original shape. Thicker gauge materials create more difficulties. An experienced operator will "pre-bend" the parts prior to the welding operation. Excessive heat and air volume create excessive stress. It is therefore recommended to work within the recommended temperature range and air volume to keep heat stress problems to a minimum.

An additional factor to take into consideration is the eventual service operating temperature of the finished product. A prime example of this phenomenon experienced by many fabricators is a PP tank with steel reinforcement. At a high operating temperature, the tank walls will expand considerably. If the steel bracing was fit too tightly around the tank, the tank will crack. To avoid this, service temperatures must be taken into consideration during the design to allow for adequate tolerances.

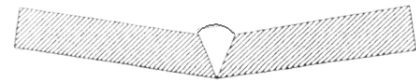

Sheet warpage caused by shrinkage during the cooling process

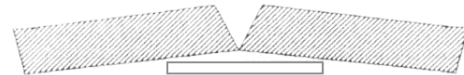

"Pre-bending" prior to welding



After welding, the sheet pulls itself straight

III. HOT GAS (AIR) EXTRUSION WELDING

1. GENERAL

Extrusion welding is an alternative to multiple pass hand welding and can be used whenever it is physically possible to operate the extruder and if the material is extrusion weldable. The benefits of extrusion welding are a minimum of heat stresses created by multiple pass hot gas hand welding and tremendous time savings.

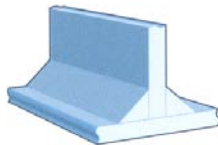

Extrusion weld



Multiple pass hand welds



Butt weld performed with Mini extrusion welder on 1/4" thick sheet

2. EQUIPMENT AND PROCEDURE

An extruder uses either pellets or welding rod as filler material. Similar to a sheet or pipe extruder, the extrusion welder includes a melting chamber with an extrusion screw, driven by an electric motor.

With a pellet extruder, the pellets are gravity fed from a hopper into the melting chamber. A rod extruder has a feed mechanism attached to the rear of the extrusion screw that pulls the welding rod into the melting chamber. Here, either the pellets or rod are chopped into small pieces by the screw, then compressed and transported to the nozzle of the extruder. The melting chamber is heated to the melting temperature of the thermoplastic material by an electric heating system. At the end of the process, a molten, homogeneous mass is expelled through the nozzle in the front of the extruder.

This molten mass runs through a PTFE shoe that is shaped according to the type and size of the weld desired. The task of the operator is to press the extruder against the parts to be welded. Provided the PTFE shoe is shaped accordingly, the emerging material will advance the extruder by itself in the direction of the weld and also dictates the welding speed. The base material is heated by a hot gas (air) preheater, which is attached to side of the machine. Sheet preparation and weld design are in principle identical to the ones applied to hand welding.

Principle of an extrusion welding machine

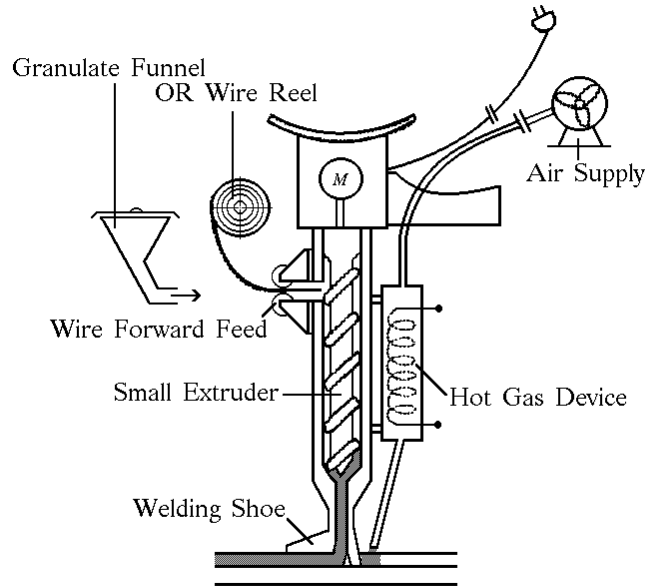

3. VISUAL CHECK OF THE FINAL WELD

Quality hot gas (air) extrusion welding is generally easier than hot gas (air) hand welding since all temperatures (melting chamber and base material preheat) are can be set prior to the welding process and can be controlled by gauges and monitored at all times. The primary function of the operator is to insure that sufficient pressure is applied and the proper speed is maintained. Too little pressure will result in the molten mass not being formed into the final bead and too much speed will cause the bead to thin out. Both of these mistakes are easy to spot on the finished product.

IV. TESTING

The means for non-destructive testing are limited. Therefore visual checking of the weld appearance is very important. A good hot gas (air) weld on most thermoplastic materials will show a slight distortion and wash along the edge of the welding rod indicating proper welding heat and pressure. A change in the surface appearance of the base material right next to the weld indicates proper preheat temperature and is referred to as HAZE (heat affected zone). A uniform appearance of the HAZE indicates constant welding speed and air volume. PVC, for example, will be shinier than the base material right next to the weld. PP and PE will have a dull appearing HAZE

If the round welding rod retains its original shape, it is a sign that an insufficient amount of pressure was applied during the weld process. If the welding rod retains its original shape and there is no shiny/dull appearance, it is a sign that the weld was performed with an excessive amount of speed. At the other end of the spectrum, excessively high weld temperature or insufficient weld speed will overheat the base material and/or the welding rod. Overheated PP and PE will look very shiny and small splashes of material seem to spray away from the bead. These visual indications are basically the only way to check large structural parts for weld integrity.

Vessels can be pressure tested and tanks can be filled with water in order to perform a leak test. Another way to test for leak free joints is by means of spark testing of the root bead. A high voltage electrode is directed to one side of the weld with conductive material on the other. In the event of a hole in the welded seam, a spark will jump through the hole indicating weld failure.

The maximum spark length is approximately 1", otherwise the insulation properties of the plastic materials would break down due to excessive voltage. This means that the spark test should be done after the first filler weld. Otherwise, a double weld failure (i.e. one at the inside weld and one at the outside weld of a tank only 2" apart) could not be detected. Some types of welds (i.e. overlap welds) cannot be spark tested at all because test probe and conductor are more than 1" apart.



High Voltage, 10 – 55 kV
AC spark tester

DVS 2207 Part 3

Recommendation for Welding Thermoplastic Materials (Sheet or Pipe)

MATERIAL TYPE	WELDING PROCEDURE	LBS OF PRESSURE REQUIRED ON WELDING ROD		AIR ³ TEMPERATURE	AIR VOLUME
		1/8" (3mm)	5/32" (4mm)		
HDPE	FH ¹	1.5 - 2.0	3.5 - 4.0	300 - 350°C	40 - 60 l/m 1.4 - 2.1 cfm
	HS ²	2.0 - 3.5	5.5 - 7.5	572 - 662°F	
LDPE	FH ¹			260 - 320°C	
	HS ²			500 - 608°F	
PP	FH ¹	1.5 - 2.0	3.5 - 4.0	280 - 330°C	
	HS ²	2.0 - 3.5	5.5 - 7.5	536 - 628°F	
PVC - HI	FH ¹	1.0 - 2.0	1.5 - 2.5	320 - 370°C	
PVC - U	HS ²	1.5 - 2.5	3.5 - 5.5	608 - 698°F	
FLEXIBLE PVC ⁴	FH ¹	3.5 - 4.0	4.0 - 5.5	320 - 370°C	
	HS ²	1.0 - 1.5	1.5 - 2.5	608 - 698°F	
CPVC	FH ¹	2.0 - 3.5	3.5 - 4.0	350 - 400°C	
	HS ²	3.5 - 4.0	4.0 - 5.5	662 - 752°F	
PMMA ⁵	FH ¹	2.5 - 3.5	2.5 - 3.5	320 - 370°C	
	HS ²	2.5 - 3.5	4.0 - 6.5	608 - 698°F	
PVDF	FH ¹	2.0 - 3.5	3.5 - 4.0	350 - 400°C	
	HS ²	2.5 - 4.0	5.5 - 7.5	662 - 752°F	

¹ Freehand weld with round nozzle

² High speed weld with high speed nozzle

³ Measured approx. 3/16" (5mm) inside the center of the round nozzle or main opening of the high speed nozzle

⁴ Pressure roller required to high speed weld this material

⁵ Welded with PVC welding rod

DVS 2207 Part 3 (Table 1)

Recommendation for Bead Design

The root bead should be carried out with 1/8" (3mm) diameter welding rod (except when the materials thickness is less than 0.080"/2mm). The subsequent filler welds can be of a larger diameter. It is preferable to scrape each weld area prior to laying the bead.

MATERIAL THICKNESS		WELDING ROD
INCHES	MM	NUMBER OF PASSES X ROD DIAMETER
Single V Bead		
0.080"	2	1 x 0.158" (4mm)
0.120" (1/8")	3	3 x 0.120" (3mm)
0.158" (5/32")	4	1 x 0.120" (3mm) + 2 x 0.158" (4mm)
0.188" (3/16")	5	6 x 0.120" (3mm)
Double V Bead		
0.158" (5/32")	4	2(1 x 0.158") (4mm)
0.188" (3/16")	5	2(3 x 0.120") (3mm)
0.250" (1/4")	6	2(3 x 0.120") (3mm)
0.313" (5/16")	8	2(1 x 0.120"/3mm + 2 x 0.158"/4mm)
0.375" (3/8")	10	2(6 x 0.120") (3mm)



SINGLE V-BEAD

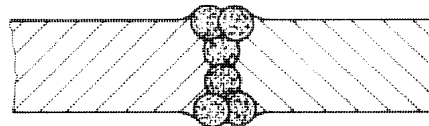

DOUBLE V-BEAD